

LONG Laboratories Over Next Generation Networks

Participants :

Portugal Telecom Inovacao (PTIN),
Telefónica I+D (TID),
Universidad Carlos III de Madrid (UC3M),
Universidad de Evora (UEV),
Universitat Politècnica de Catalunya (UPC),
Universidad Politécnica de Madrid (UPM).

LONG: Laboratories Over Next Generation Networks.



General Information

- **LONG: Laboratories Over Next Generation Networks.**
 - **IST Programme of EU: IST-1999-20393.**
 - **Participants: PTIN, TID, UC3M, UEV, UPC, UPM.**
 - **Project Coordination: TID.**
 - **Start Date: 1/12/2000. Duration: 24 Months.**

 - **Management, Coordination and Dissemination Work Packages:**
 - WP 1: Management and Coordination.
 - WP 5: Dissemination of the Results.

 - **Technical Work Packages:**
 - WP 2: Network Design and Deployment.
 - WP 3: Collaborative Work Environment.
 - WP 4: System Trials and Evaluation.

LONG: Laboratories Over Next Generation Networks.



WP 2: Network Platform (I)

- **Main Activities:**

- **A2.1 Interoperability IPv4-IPv6 scenarios definition and transition strategies. Apart from theoretical studies and combinations, we have focused on examining concrete actual networks and use transition mechanisms only when needed to access non-migrated services.**
- **A2.2 Evaluate several access and transport technologies as well as their IPv6 interaction.**
 - State of the art of IPv6 over different access/transport technologies.
 - Practical experiments to perform functionality tests and evaluate standards compliance.
 - Tested technologies: Ethernet, GigabitEthernet, ATM, ADSL, CATV, ISDN, WLAN.
 - Planned Tests: POS, DWDM.
 - Different router vendors: Cisco, Ericsson-Telebit, 3COM.
 - Different OS for hosts: FreeBSD, Linux, Solaris and Windows (NT4.0/2000)



WP 2: Network Platform (II)

- **A2.3: Deployment of an IPv6 access platform and interconnection.**

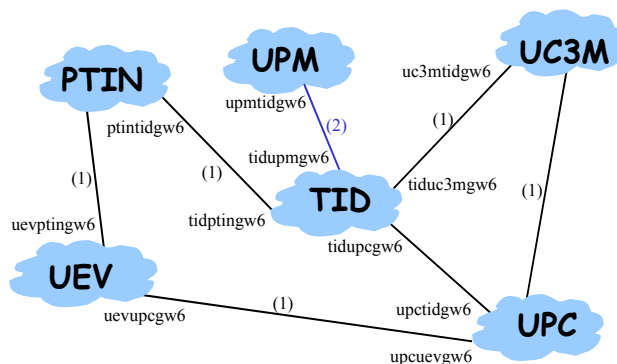

Current Services

- Private DNS system: A/AAAA queries over IPv6 protocol.
- WEB Servers and FTP servers.
- BGP4+ peering (testing now)
- Network Statistics related to network stability (will be available in our WEB Server)

Links

- (1) IPv6-IPv4 Configured Tunnel over Internet.
- (2) Native IPv6 over ATM (5 Mbps).



WP 2: Network Platform (III)

- **A2.4 Activities to be performed on this IPv6 Platform:**
 - Evaluate new services in next generation networks: QoS, Multicast, Mobility and Security.
 - Continue the activities mentioned before (A2.1, A2.2 and A2.3) using the IPv6 platform facilities.
 - Integration of IPv4/IPv6 networks and services.
 - Verify the real state of the art, support, standards compliance and IPv4 interaction strategies of IPv6 protocol.



WP 3: Collaborative Environment (I)

- **Main Activities:**
 - **Adapt an application set from IPv4 to IPv6: ISABEL (CSCW), MGEN (traffic generator/analyzer), etc.**
 - **Develop documentation about IPv6 application migration and the use of the new features.**
- **Status:**
 - **Now:**
 - Using ISABEL CSCW application (<http://isabel.dit.upm.es>) over IPv4.
 - Most links are temporary links IPv4 over ATM.
 - All project meetings (but the kick-off) were performed with this platform. We used REDIRIS, FCCN and DANTE Academic and Research networks, saving about 14,712 Euro (Estimation based in the kick-off travel costs).
 - This infrastructure was used to distribute IPv6 Global Summit (Madrid, Feb-2001) to nodes in Barcelona, Valencia, Murcia, Aveiro, Ljubljana and Ottawa.



LONG Project Coordination Meetings

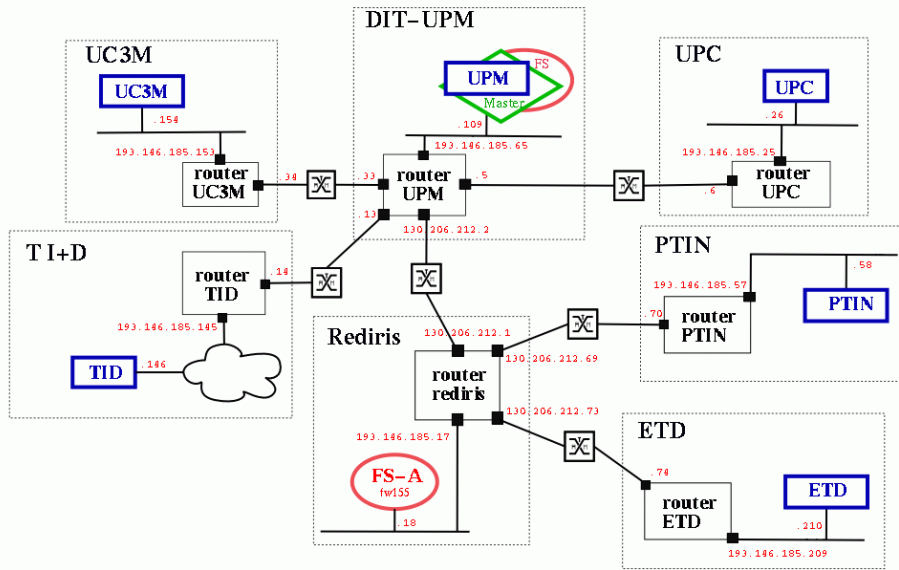

LONG: Laboratories Over Next Generation Networks.



Madrid Global IPv6 Summit 2001

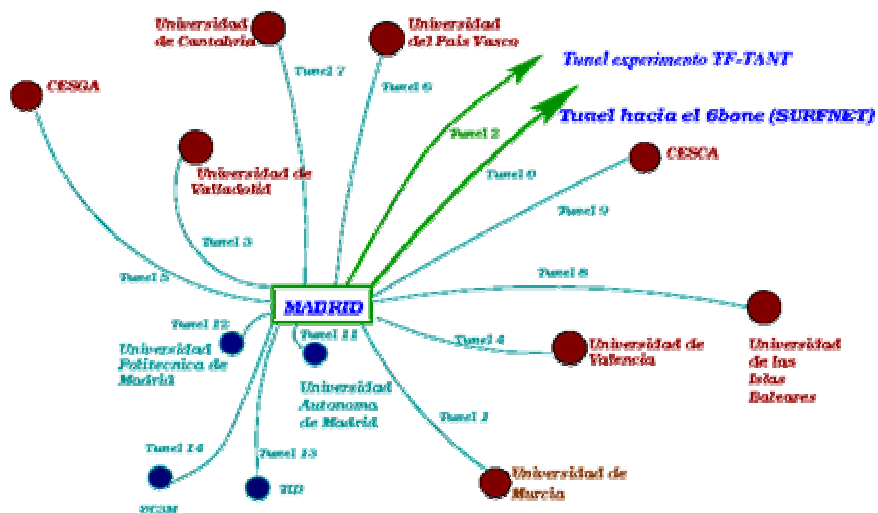

LONG: Laboratories Over Next Generation Networks.



WP 3: Collaborative Environment (II)

■ Next Step:

- ISABEL IPv6 enabled: all partners will be connected with 2 Mbps IPv6 links when testing and distributing meeting/events. At least one link will be native IPv6 over ATM. Other links will be IPv6 tunnels over IPv4/ATM.
- We plan to distribute one wide event using IPv6 technology during next year.

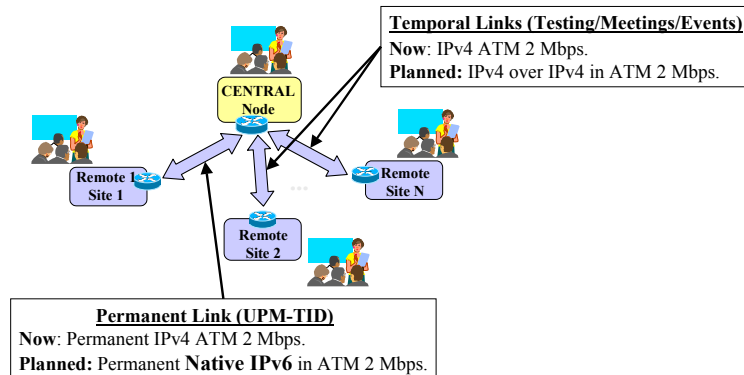

LONG: Laboratories Over Next Generation Networks.



WP 4: Experiences and Tests

● Main Activities:

- **A4.1 Carry out tests: configuration, stability and capabilities of network components and network mechanisms.**
 - Since Functionality tests are done in WP2 context, here we make performance tests of:
 - Access Technologies: ADSL, ISDN, WLAN, CATV.
 - Transport Technologies: ATM, GE, POS.
 - Transition Mechanisms: Tunnels (configured, automatic, 6to4), NAT-PT and Socks.
 - These tests are made with MGEN migrated to IPv6 (get it now in our WEB server!).
 - We plan to perform tests related to:
 - Routing protocols stability and performance.
 - Advanced services support and performance.
- **A4.2 Fulfill tele-meeting experiences and/or tele-conference to evaluate in an accurate way the defined platforms and perform real traffic measurements.**

LONG: Laboratories Over Next Generation Networks.



Workpackage Description

LONG: Laboratories Over Next Generation Networks.



WP2 Network Design and Deployment

- **Study and evaluation of Transition Mechanisms**
- **Test available implementations**
- **Test for support of transition mechanisms on current equipment**

LONG: Laboratories Over Next Generation Networks.



Transition Mechanisms

- **Dual-Stack nodes**
- **Tunneling Mechanisms**
 - Configured Tunneling
 - Automatic Tunneling
 - 6to4
 - Tunnel Broker
 - DSTM (Dual Stack Transition Mechanism)
- **Translation Mechanisms**
 - NAT-PT (NAT Protocol Translation)
 - Socks64
 - BIS (Bump-In-the-Stack)
 - TRT (Transport Relay Translator)



Dual-Stack nodes

- **Both IPv4 address and IPv6 address**
- **DNS resolver must handle A type and A6/AAAA type records**

- **Dual-Stack nodes**
 - FreeBSD, Linux, Windows, Solaris



Transition Scenarios

- **Connection of IPv4 and IPv6 networks**

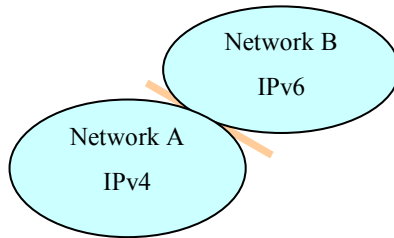

- **Applicable mechanisms:**

- DSTM
- NAT-PT
- SOCKS64
- TRT

Transition Scenarios

- **Interconnection of Networks**

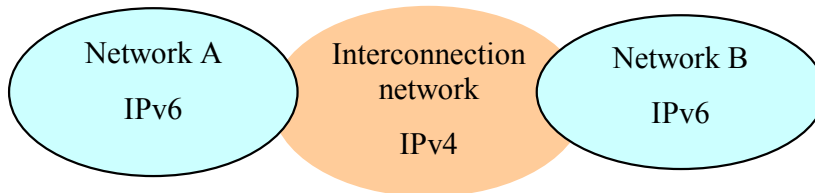

- **Applicable mechanisms:**

- Tunneling Mechanisms
- 6to4 (most suitable)
- 6over4 (some restrictions apply; not recommended)
- NAT-PT (not recommended)

Transition Scenarios

- **Interconnection of Networks**

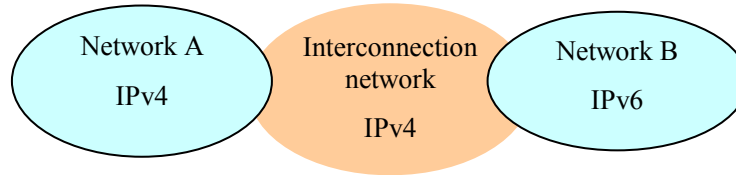

- **Applicable mechanisms:**
 - DSTM
 - NAT-PT (not recommended)
 - SOCKS64
 - TRT

Transition Scenarios

- **Interconnection of Networks**

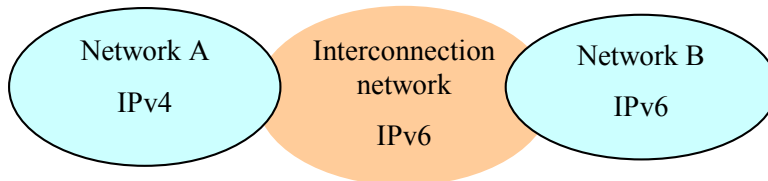

- **Applicable mechanisms:**
 - DSTM (some restrictions apply)
 - NAT-PT
 - SOCKS64
 - TRT (not recommended)

Transition Scenarios

- **Interconnection of Networks**

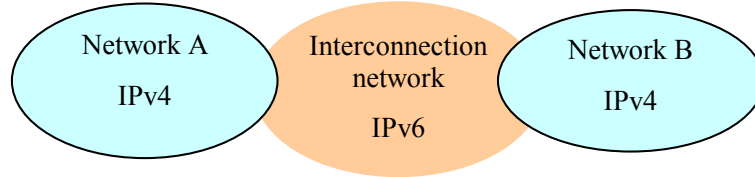

- **Applicable mechanisms:**
 - NAT-PT (not recommended)

Transition Scenarios

- **Isolated Host**

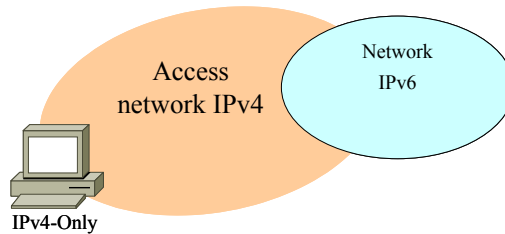

- **Applicable mechanisms:**
 - DSTM
 - NAT-PT
 - SOCKS64
 - TRT

Transition Scenarios

- **Isolated Host**

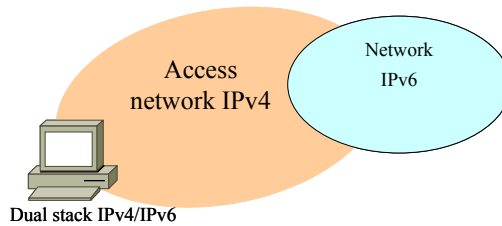

- **Applicable mechanisms:**

- Tunneling Techniques
- 6to4
- 6over4
- NAT-PT
- SOCKS64

Transition Scenarios

- **Isolated Host**

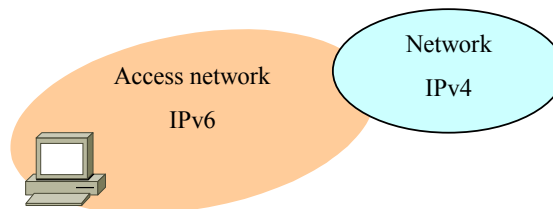

- **Applicable mechanisms:**

- DSTM
- NAT-PT
- SOCKS64
- TRT

Available Implementations Tested

- **NAT-PT**
 - MS Windows NATP, FreeBSD
- **6to4**
 - Linux, FreeBSD
- **BIS**
 - Windows 98/NT4.0 (Toolnet6)
- **DSTM**
 - FreeBSD 3.4, NetBSD 1.4.1
- **DSTM Configured Tunnels**
 - Linux, Solaris, Cisco, Windows NT 4.0
- **Automatic Tunnels**
 - Cisco
- **Tunnel Broker**
 - CSELT IPv6 Tunnel Broker (Linux), FreeBSD KAME Tunnel Server, Dual Stack Linux Client

LONG: Laboratories Over Next Generation Networks.



Available Implementations Tested

- **SOCKS64**
 - NEC SOCKSv5 for Linux and Solaris

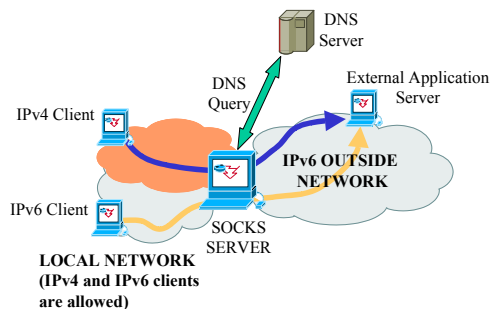

- **TRT**
 - **KAME:** BSD/OS 3.1 and 4.2, FreeBSD 2.2.8 and 4.2, NetBSD 1.5, OpenBSD 2.8.
 - ***BSD:** FreeBSD 4.0, NetBSD 1.5, OpenBSD 2.7, BSD/OS 4.2 and beyond

LONG: Laboratories Over Next Generation Networks.



Support for Tunneling Mechanisms

	Solaris	FreeBSD	Linux	Windows		Cisco	Telebit
				2000	NT		
Automatic Tunnels	✓		✓	✓	✓	✓	✓
Configured Tunnels	✓	Standard FreeBSD > 4.0-RELEASE	✓	✓	✓	✓	✓
6to4 Tunnels	✓	Standard FreeBSD > 4.0-RELEASE	> 2.2.16 (for 2.2.X) and 2.4.0	✓	✓	✓	
	Solaris	FreeBSD	Linux	Windows		Cisco	Telebit
				2000	NT		
6over4				✓	✓		

LONG: Laboratories Over Next Generation Networks.



Support for Translation Mechanisms

	FreeBSD	Linux	Windows 2000	Cisco	Telebit
NAT-PT	Kame	Provided by Korean IPv6 Forum	Microsoft's MSIPv6 1.4 on Windows 2000	IOS 12.2(2)T	Minimal implementation (IPv4/IPv6 header translation)
NAT (IPv4)	FreeBSD standard	Linux 2.4 and above		✓	
TRT	Kame		✓		
SOCKs		Software provided by NEC	Software provided by NEC		

LONG: Laboratories Over Next Generation Networks.



Transition Mechanisms

- **The deployment of IPv6 must be done in a smooth way to prevent the disruption of the actual IPv4 infrastructure. To allow a gradual transition, several mechanisms have been developed to guarantee the interoperability of IPv4 and IPv6.**
- **All the transition mechanisms have different characteristics. Their applicability depends on the requirements defined for a given transition scenario. Also, one transition scenario may require the simultaneous use of several mechanisms.**

Transition Mechanisms

- **Some mechanisms may be more adequate for an early stage of transition (IPv6 islands in an IPv4 ocean) while others are more appropriate for intermediate or final transition stages. It is also believed that some mechanisms will be applied in all stages, and that the transition period will be long.**
- **The available implementations are still limited. Some of them are implemented on only certain operating systems. The majority of the implementations work in personal computers but in the future the manufacturers of network equipment will implement these mechanisms.**

WP3 Collaborative Work Environment

- **Basic aspects of application migration to IPv6**
- **Classification of applications for migration to IPv6**



Application Migration to IPv6

- ***Non networking applications***: Applications that do not establish communication channels with other applications or processes.
 - **No porting is needed (check IPv6 related information)**
- ***Site-local networking applications***: Applications that establish communication channels with other applications or processes in the same node.
 - **No porting is needed. If it is an IPv6 host use API extensions**
- ***Global networking applications***: Applications that establish communication channels with other applications in other different nodes using IPv4 protocol.
 - **Application porting is required**



Dual Stack and Client/Server Applications

		IPv4 server application		IPv6 server application	
		IPv4 node	Dual-stack	IPv6 node	Dual-stack
IPv4 client	IPv4 node	IPv4	IPv4	X	IPv4
	Dual-stack	IPv4	IPv4	X	IPv4
IPv6 client	IPv6 node	X	X	IPv6	IPv6
	Dual-stack	IPv4	IPv4 / X	IPv6	IPv6

Types of Applications

- **IPv4-only:** An application that is not able to handle IPv6 addresses, i.e. it can not communicate with nodes that do not have an IPv4 address.
- **IPv6-aware:** An application that can communicate with nodes that do not have IPv4 addresses, i.e. the application can handle the longer IPv6 addresses. In some cases this might be transparent to the application, for instance when the API hides the content and format of the actual addresses.
- **IPv6-enabled:** An application that, in addition to being IPv6-aware, takes advantage of some IPv6 specific features such as flow labels. The enabled applications can still operate over IPv4, perhaps in a degraded mode.
- **IPv6-required:** An application that requires some IPv6 specific feature and therefore can not operate over IPv4.

Protocol Independent Applications

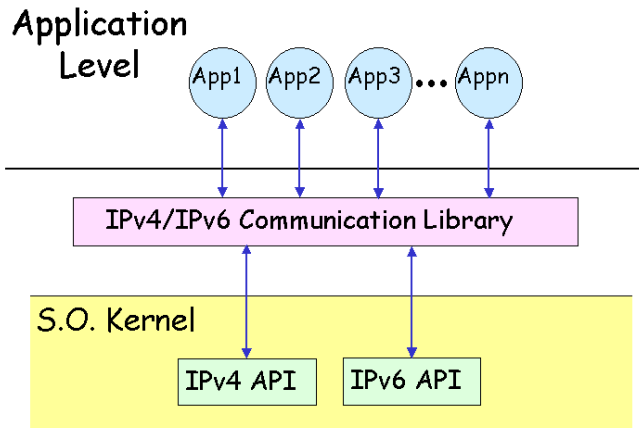

LONG: Laboratories Over Next Generation Networks.



Application Migration

- The migration of applications is not too much difficult. It can be made in parallel with network migration and after the provision of a DNS service (and maybe a NIS service).
- It is clear that the feasibility for a particular portion of code to be ported to IPv6 depends on its own context and the process can not be defined rigidly. However, it can be said that, for a simple networking interface, the porting is quite straightforward and, sometimes can be automated.
- Applications with changes in the interface or addition of new functionalities require too much effort, forcing the programmer to analyse and rewrite more than the code that access to the simple sockets interface.

LONG: Laboratories Over Next Generation Networks.



LONG - Laboratories Over Next Generation Networks - Netscape

File Edit View Go Communicator Help

Back Forward Reload Home Search Netscape Print Security Shop Stop

Bookmarks Location: http://long.ccaba.upc.es/



Activities

Global IPv6 Summit (Madrid 2001) LONG Presentation ([1 slide/page](#)) ([2 slide/page](#))

<http://www.consulintel.es/Html/ForoIPv6/madridgishome.htm> (spanish)
<http://www.consulintel.es/Html/ForoIPv6/madridgishomeeng.htm> (english)

Participation in Workshop about "Advanced Network Usage" promoted by FCCN 21/03/2001
<http://www.fccn.pt/workshop/>

<http://www.fccn.pt/> Fundação para a Computação Científica Nacional

Software tool distribution At Universidad Carlos III (UC3M), in LONG project framework, they have migrated MGEN application to IPv6 so that it can generate and receive all kind of IPv6 packets (including Hop by Hop options, routing header and destination options).
[Download MGEN6](#)

IMPORTANT: When installing MGen6 remember to change some variables (SYSTEM_PATH and SYSTEM_CFLAGS) in "Makefile" depending on your operative system (Linux or FreeBSD). If you still have compilation errors make sure you have <netinet/in.h> and <netinet/ip6.h> in your default include directory (usually "/usr/include").

ccaba@ac.upc.es

Last update: March 02, 2001.

Last update: March 02, 2001.

Related Projects

ccaba@ac.upc.es

Last update: March 02, 2001.

LONG - Laboratories Over Next Generation Networks - Netscape

File Edit View Go Communicator Help

Back Forward Reload Home Search Netscape Print Security Shop Stop

Bookmarks Location: http://long.ccaba.upc.es/



Index of /~/long/software/mgen6/mgen6

Name	Last modified	Size	Description
Parent Directory	04-Oct-2001 13:43	-	
CHANGELOG	22-Oct-2001 10:24	1k	
MGEN_README	04-Oct-2001 13:54	22k	
MGENv6_README	04-Oct-2001 13:54	4k	
REPORTING_BUGS	04-Oct-2001 13:54	1k	
TODO	04-Oct-2001 13:54	1k	
VERSION	04-Oct-2001 13:54	6k	
mgen6-v3.2.0.tgz	10-Oct-2001 15:35	239k	GZIP compressed tar ar>
mgen6-v3.2.1.tgz	15-Oct-2001 13:23	239k	GZIP compressed tar ar>
mgen6-v3.2.2.tgz	22-Oct-2001 10:24	239k	GZIP compressed tar ar>
mgenTest6_new.sh	22-Oct-2001 10:09	15k	
old mgen6 1/	17-Jul-2001 19:33	-	
old mgen6 2/	04-Oct-2001 13:58	-	
old mgen6 3/	22-Oct-2001 11:44	-	
patch-20011030.gz	30-Oct-2001 18:16	1k	GZIP compressed docume>
result6.xls	04-Oct-2001 13:58	89k	

-----> The batch "batch-20011030.gz" is for version 3.2.2 <-----

LONG: Laboratories Over Next Generation Networks.



WP4 System Trials and Evaluation

- Measurement methodology
- IPv4/IPv6 Transition Mechanisms Testing
- Access and Transport Technologies Testing for IPv6

Experiences and Results (example)

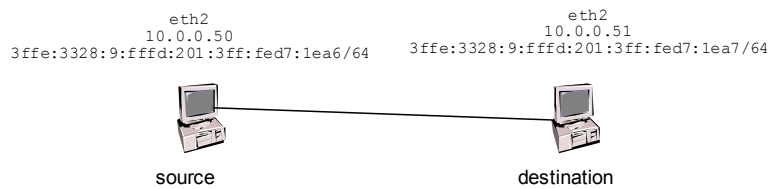

MGEN IPv4

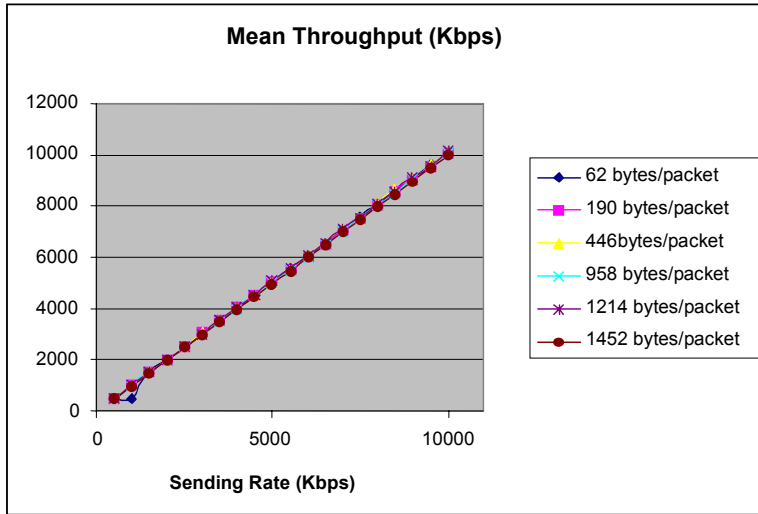

LONG: Laboratories Over Next Generation Networks.



MGEN IPv4

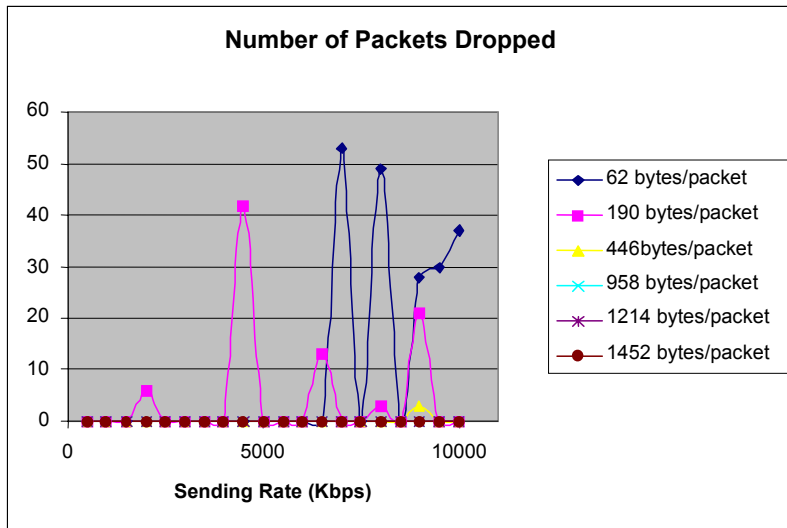

LONG: Laboratories Over Next Generation Networks.



MGEN IPv4

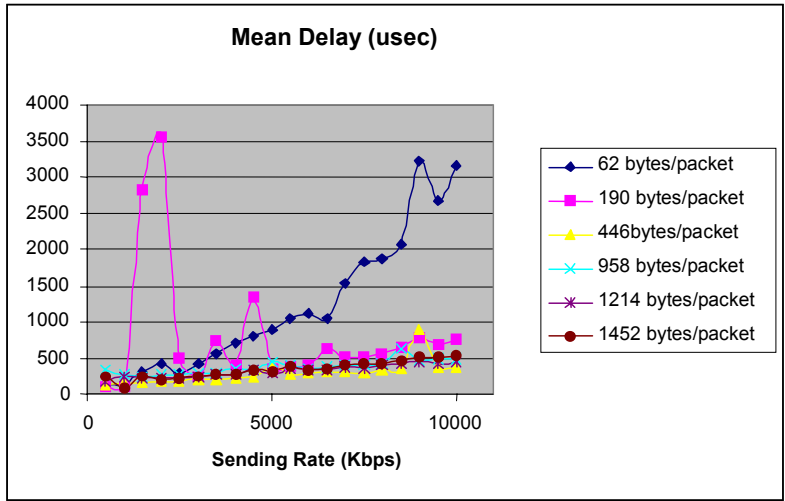

LONG: Laboratories Over Next Generation Networks.



MGEN IPv4

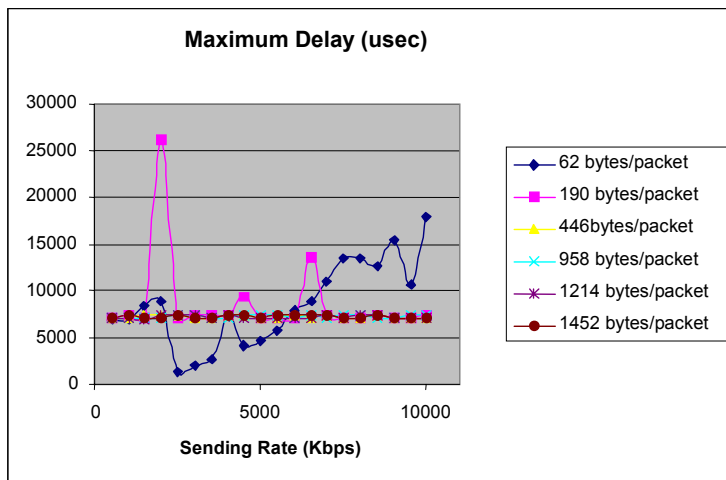

LONG: Laboratories Over Next Generation Networks.



MGEN IPv4

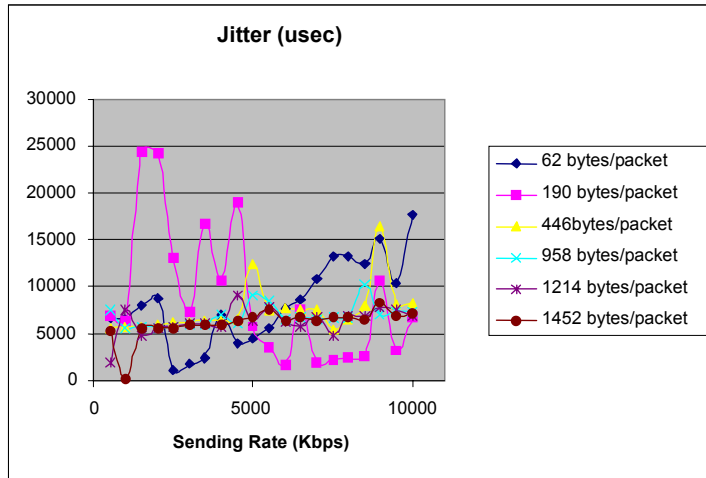

LONG: Laboratories Over Next Generation Networks.



MGEN IPv6

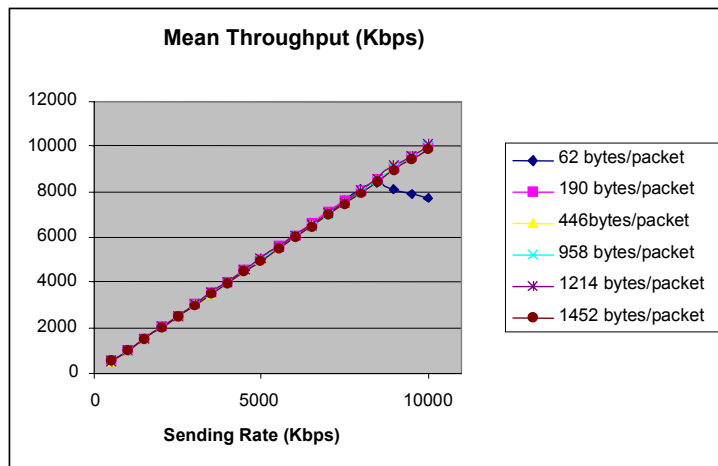

LONG: Laboratories Over Next Generation Networks.



MGEN IPv6

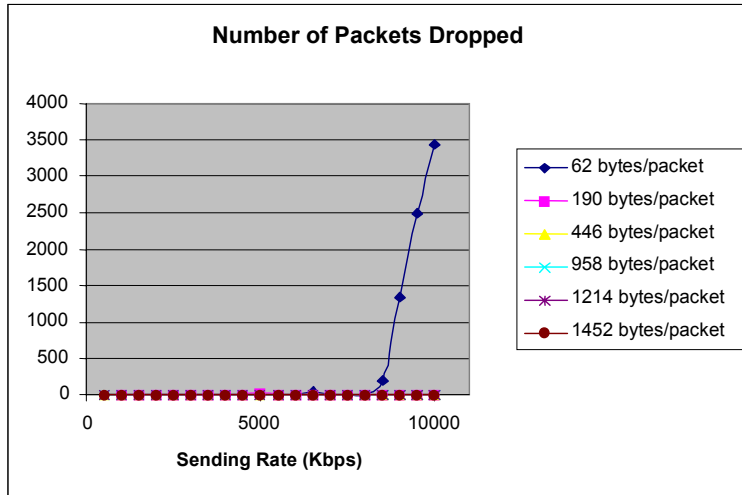

LONG: Laboratories Over Next Generation Networks.



MGEN IPv6

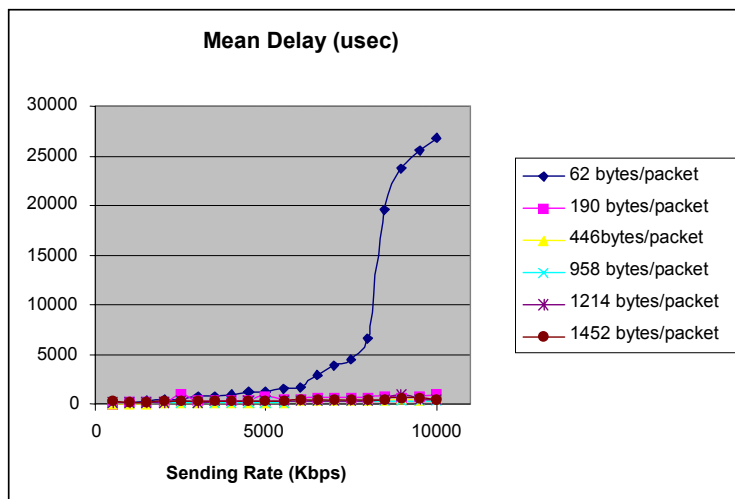

LONG: Laboratories Over Next Generation Networks.



MGEN IPv6

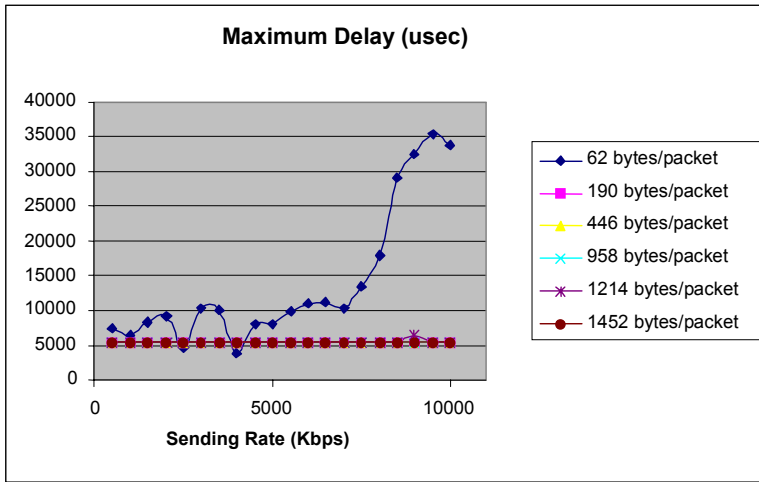

LONG: Laboratories Over Next Generation Networks.



MGEN IPv6

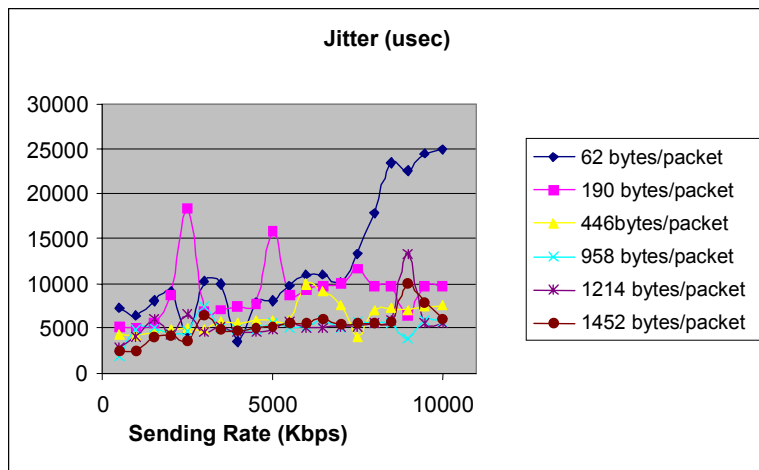

LONG: Laboratories Over Next Generation Networks.



IPv4 – IPv6 Performance Comparison

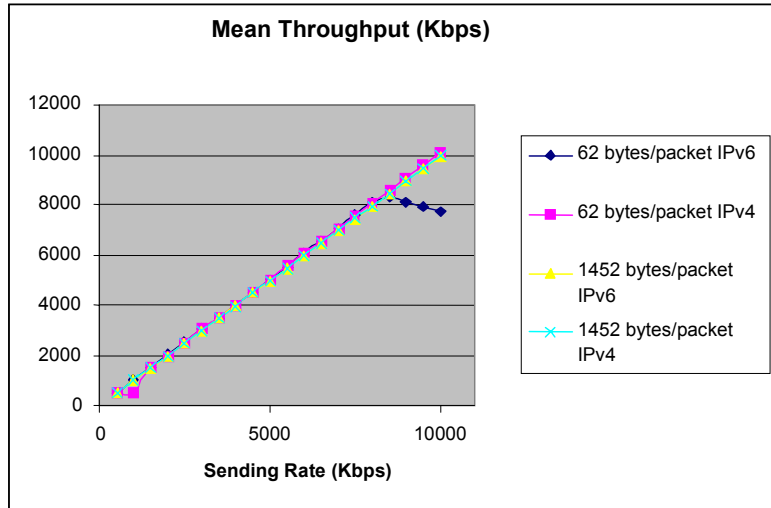

LONG: Laboratories Over Next Generation Networks.



IPv4 – IPv6 Performance Comparison

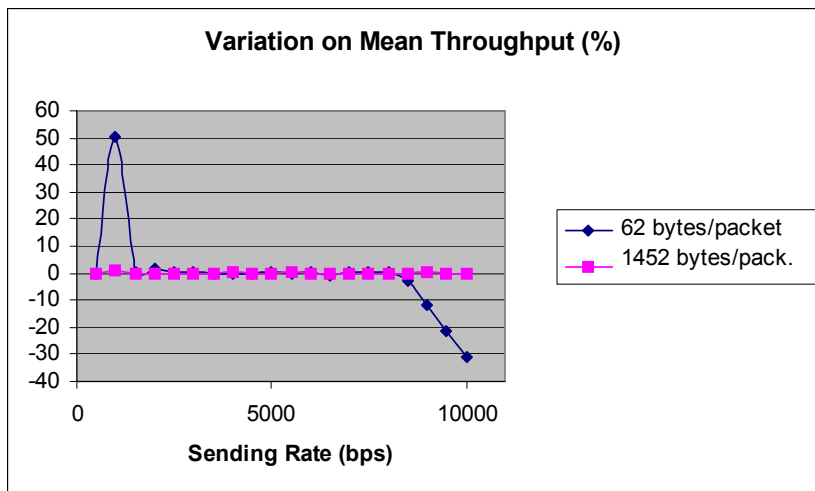

LONG: Laboratories Over Next Generation Networks.



IPv4 – IPv6 Performance Comparison

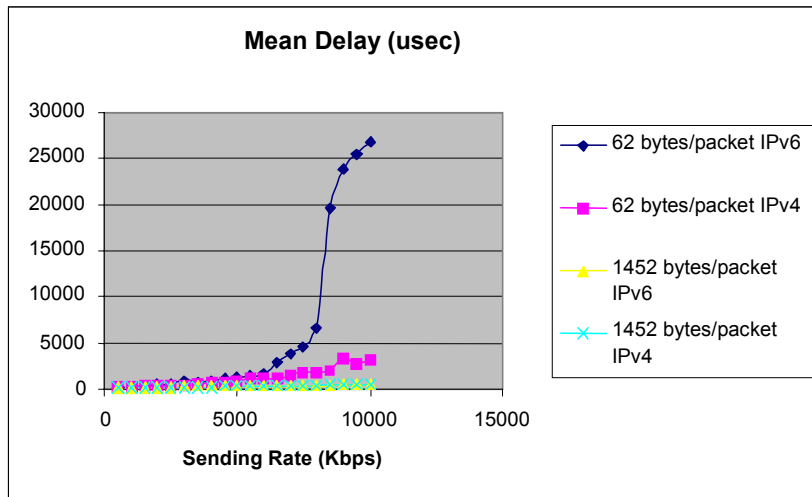

LONG: Laboratories Over Next Generation Networks.



Collaborations

- **Possible Synergies and Collaboration with:**

- “Next Generation Networks” development teams.
- Advanced IPv6 Applications development groups.
- Collaborative Work Applications development groups.

- **Contact:**

- Contact mailing list: long-committee@ac.upc.es
- Jordi Domingo-Pascual: (WP5 Leader) jordi.domingo@ac.upc.es
- Carlos Ralli Ucendo: (Co-ordinator) ralli@tid.es

- **Public WEB Site: long.ccaba.upc.es**

- Deliverables available

LONG: Laboratories Over Next Generation Networks.

